

SURFACE MOUNTED SHIELD WITH PASS THROUGH

410.13-15 | Protective Acrylic Shield - 1/4" Gauge

These drawings have not been reviewed and approved by the architect and cannot ever be used for construction purposes. These drawings are for the exclusive use of Lumicor. Any use of these drawings by others will be at their own risk and lumicor will not be responsible for issues that may arise from their use.

© Lumicor 2020 — All Rights Reserved. For more information, visit www.lumicor.com or call 1.888.LUMICOR (888.586.4267)

Solution
410.13-15

1/6/21

Page 1 of 2

PARTS LIST

ITEM NUMBER	PART DESCRIPTION	QTY PER FEATURE
1	GRIPPER	4
2	MOUNTING SCREW	4
3	NYLON TIPPED SET SCREW	4
4	PROTECTIVE ACRYLIC SHIELD	1

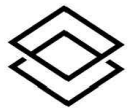
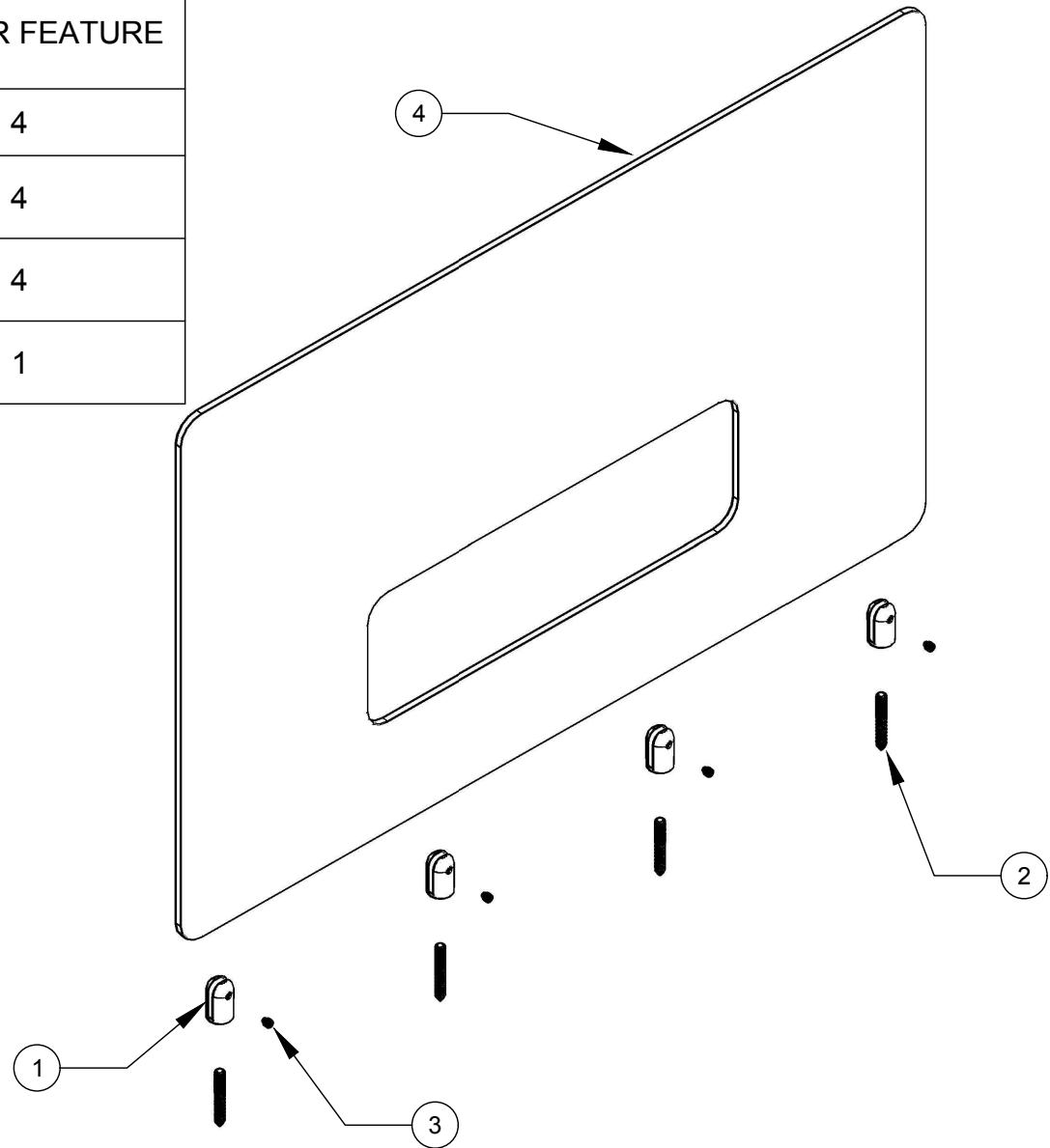

Lumicor.

SURFACE MOUNTED SHIELD WITH PASS THROUGH

410.13-15 | Protective Acrylic Shield - 1/4" Gauge

These drawings have not been reviewed and approved by the architect and cannot ever be used for construction purposes. These drawings are for the exclusive use of Lumicor. Any use of these drawings by others will be at their own risk and lumicor will not be responsible for issues that may arise from their use.

© Lumicor 2020 — All Rights Reserved. For more information, visit www.lumicor.com or call 1.888.LUMICOR (888.586.4267)

Solution
410.13-15

1/6/21

Page 2 of 2