

BASE MOUNT HOLE  
DRILLED 180° FROM GRIPPER



## WALL-MOUNTED PONY WALL POST PARTITION

409.01 | .354 Single Section

These drawings have not been reviewed and approved by the architect and cannot ever be used for construction purposes. These drawings are for the exclusive use of Lumicor. Any use of these drawings by others will be at their own risk and lumicor will not be responsible for issues that may arise from their use.

© Lumicor 2019 — All Rights Reserved. For more information, visit [www.lumicor.com](http://www.lumicor.com) or call 1.888.LUMICOR (888.586.4267)

Solution  
409.01

10/22/20

Page 1 of 2

# BILL OF MATERIALS

ITEM NUMBER	QUANTITY PER CONFIG	PART DESCRIPTION
1	1	CONCRETE ANCHOR
2	1	INTERNAL BASE MOUNT WITH [3] $\frac{5}{16}$ "-18 X $\frac{3}{8}$ " BUTTON SOCKET SET SCREW
3	6	$\frac{3}{8}$ " GRIPPER
4	6	$\frac{5}{16}$ "-18 X $\frac{5}{8}$ " STEEL STUD
5	6	WASHER
6	6	$\frac{1}{4}$ "-20 SET SCREW
7	1	CLEAR PVC TUBING
8	1	2.5" DIA FREE STANDING POST
9	1	POST CAP WITH GASKET

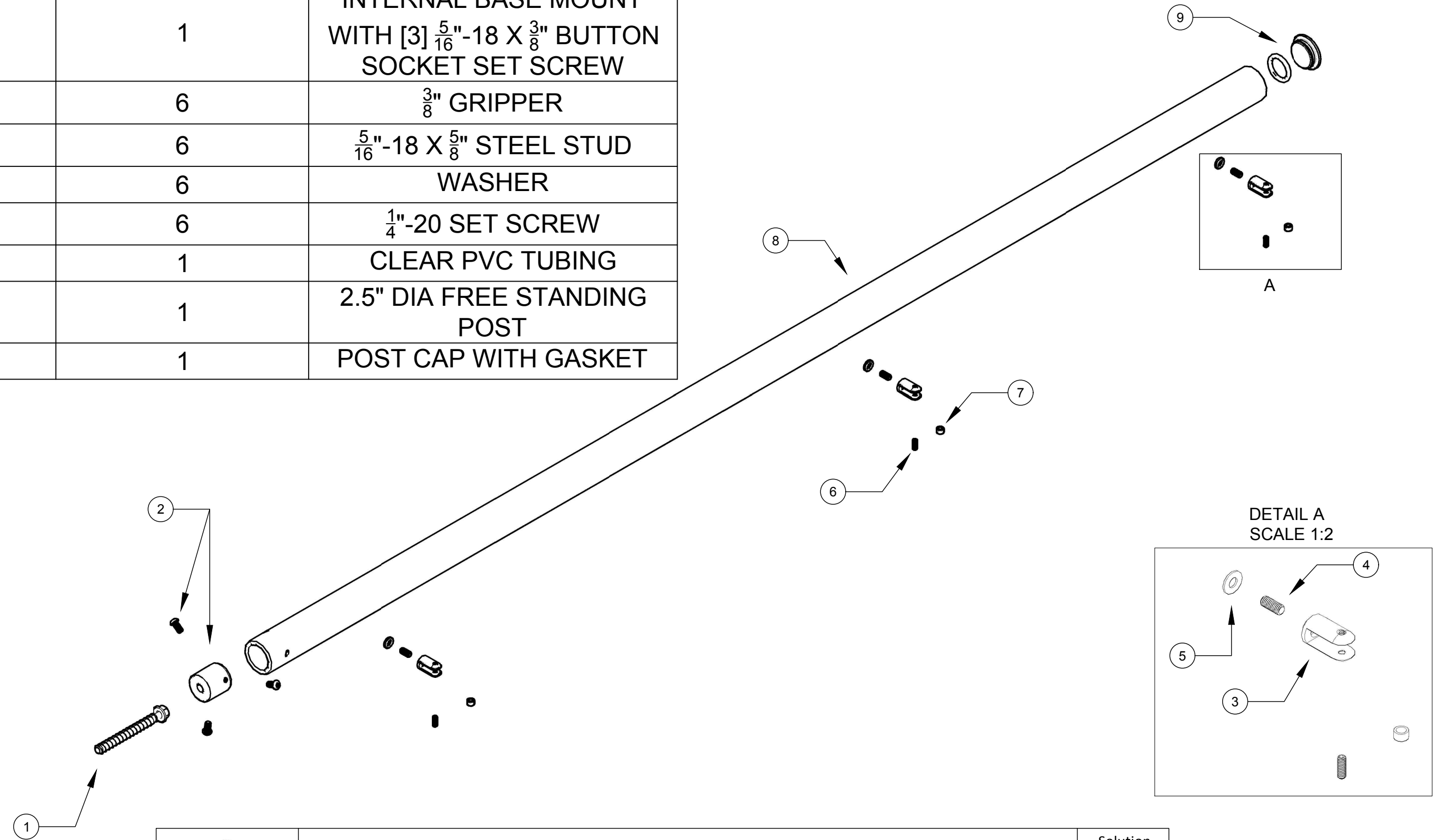

	<b>WALL-MOUNTED PONY WALL POST PARTITION</b> 409.01   .354 Single Section	Solution 409.01
	<small>These drawings have not been reviewed and approved by the architect and cannot ever be used for construction purposes. These drawings are for the exclusive use of Lumicor. Any use of these drawings by others will be at their own risk and lumicor will not be responsible for issues that may arise from their use.</small>	10/22/20
	<small>© Lumicor 2019 — All Rights Reserved. For more information, visit <a href="http://www.lumicor.com">www.lumicor.com</a> or call 1.888.LUMICOR (888.586.4267)</small>	Page 2 of 2